

REVISIONS			
REV.	DESCRIPTION	DATE	APPROVED

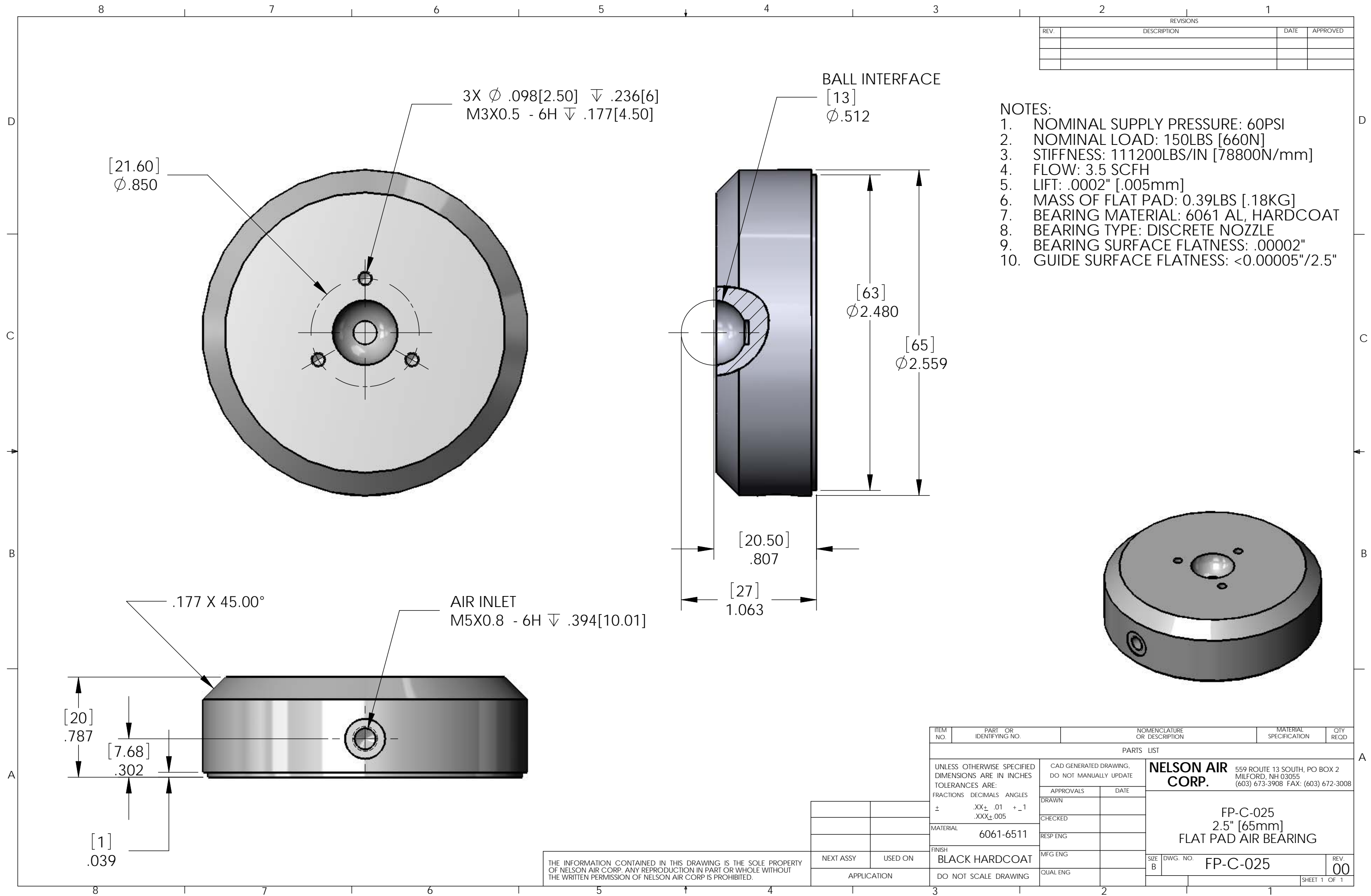

- NOTES:
1. NOMINAL SUPPLY PRESSURE: 60PSI
 2. NOMINAL LOAD: 150LBS [660N]
 3. STIFFNESS: 111200LBS/IN [78800N/mm]
 4. FLOW: 3.5 SCFH
 5. LIFT: .0002" [.005mm]
 6. MASS OF FLAT PAD: 0.39LBS [.18KG]
 7. BEARING MATERIAL: 6061 AL, HARDCOAT
 8. BEARING TYPE: DISCRETE NOZZLE
 9. BEARING SURFACE FLATNESS: .00002"
 10. GUIDE SURFACE FLATNESS: <0.00005"/2.5"

ITEM NO.	PART OR IDENTIFYING NO.	NOMENCLATURE OR DESCRIPTION	MATERIAL SPECIFICATION	QTY REQD
PARTS LIST				
UNLESS OTHERWISE SPECIFIED DIMENSIONS ARE IN INCHES TOLERANCES ARE:		CAD GENERATED DRAWING, DO NOT MANUALLY UPDATE		NELSON AIR CORP. 559 ROUTE 13 SOUTH, PO BOX 2 MILFORD, NH 03055 (603) 673-3908 FAX: (603) 672-3008
FRACTIONS DECIMALS ANGLES		APPROVALS	DATE	
±	.XX± .01 +_1	DRAWN		FP-C-025 2.5" [65mm] FLAT PAD AIR BEARING
	.XXX±.005	CHECKED		
MATERIAL	6061-6511	RESP ENG		
FINISH	BLACK HARDCOAT	MFG ENG		
NEXT ASSY USED ON		QUAL ENG		SIZE B DWG. NO. FP-C-025 REV. 00
APPLICATION		DO NOT SCALE DRAWING		SHEET 1 OF 1

THE INFORMATION CONTAINED IN THIS DRAWING IS THE SOLE PROPERTY OF NELSON AIR CORP. ANY REPRODUCTION IN PART OR WHOLE WITHOUT THE WRITTEN PERMISSION OF NELSON AIR CORP IS PROHIBITED.